

Please read carefully before starting operation !

- Should any damage occur due to disregard of the following instructions the guarantee expires and the manufacturer is free from any obligations. The device can only be employed under operations parameters not exceeding the nominal capacity of the clutch or brake. Maximum torque and highest permissible power loss must be strictly observed. The available voltage must correspond to the operation voltage indicated on the identification plate. When a clutch of the E(R)AT ... -Type is used, the distance between the brush holders and the slide ring must correspond to the measure indicated on the table of dimensions.
If a brake is used, there is no slide ring and the connection is effectuated directly on the coil. Thereupon it must be checked that no body contact takes place.
If a clutch or a brake is operated in an extremely dustladen place (soot, wood chip, paper or cement dust) a dust cover should be provided. In such a case an additional fan should allow reliable dissipation of the heat developed.

Storage : Clutches and brakes must be stored in a dry place and protected against corrosion. The device can only be stored in its welded plastic hull containing moisture absorbing chips.

- Installation :
Installation of the device must be carried out with care in order to prevent damaging of bearing and packing. Any use of force impairs the function. The borehole present should be lightly smeared with a rust proofing grease. The system being lubricated for life, any other lubrication with oil or grease is not admitted as it would impair the performance of the device.
- Starting operation :
Clutches and brakes should be taken into operation by means of short current pulses to allow proper distribution of the magnetic particles. Thereupon the rotor speed correspond to the use required.
- Dismounting, Repairs :
Instructions for repair are supplied on request free of obligation. Upon disassembly of clutches and brakes any shock by knocks and shoves must be prevented. When removing the rotor a brace can be used.

c			Datum	29.12.1993	Zeichnungsnummer/ drawing number			operating instructions	Komm.Nr		Vertragsnummer
b			Bearb.	KIPP	1.1232E						
a			Gepr.								
	Änderung	Datum	Name	Norm	Einbauort:	Ersatz fuer:	Ursprung:	18.09.2014	General-Information		Blatt 1
										1 Bl.	

Repair instructions :

Clutches EAT 10001 331 220 00 ERAT 10001 331 230 00

Brakes FAT 10 001 331 200 00 FRAT 10001 331 210 00

FRATO 10001 331 240 00
FRATO 10001 R 331 250 00

"R" = heat sink
"O" = watercooling

The magnetic particle clutch / brake should be disassembled in the following order :

During assembly, refer to the sectional drawing.

1. To disassemble, place the clutch / brake on a workbench with the slipring or coil connectors up. Disconnect the slipring from the coil, and remove the screws to lift the slipring from the housing.
2. Loosen the screws on the bearing shell to remove the bearing shell together with the internal rotor. The housing with the coil is now accessible.
3. After removing the circlip ring from the ball bearing, lift the ball bearing and seals from the bearing shell.
4. Clean the inner side of the housing and the internal rotor carefully of magnetic powder.
5. Fit the new seals and ball bearings in the bearing shell and fix them on the bearing cover using the circlip ring. Before that, slide the seals (V ring) on the hollow shaft of the internal rotor. Push the internal rotor into the ball bearing of a bearing shell and fix it in position using a circlip ring.
6. Housings fitted with heat sink, e.g. Type ERAT ... FRAT... have the heat sinks shrunk on. Heat them slightly if they need to be pulled off. As clutches are balanced with the heat sink fitted, be sure to re-fit it in exactly the same position.

Important note !

The magnetic powder must be poured into the air gap / space between the internal rotor and the external rotor (not into the hollow space in which the field coil is located). Be sure to use only the amount and particle size of magnetic powder approved for the particular type of clutch / brake.

The old magnetic powder must not be re-used.

Then replace the internal rotor with the housing cover and screw it down. Secure the slipring assembly and make the connections with the coil.

Following assembly, place the clutch/ brake in its fitting position, i.e. with its hollow shaft horizontal.

Push the internal rotor into the hollow shaft revolving at low speed while tapping on the rotor.

This distributes the magnetic powder evenly in the air gap.

This distributes the magnetic powder evenly in the air gap.

Spare parts :

*) Only available as complete repair kit

	Pcs	Type 10001	Bestell- Nr
	1	Internal rotor	331 200 06
	1	Field coil 24VDC	331 200 14
	1	Brush holder assy.	314 310 60
	1	Slip ring	314 201 40
	4	Carbon brush holder 17x10x5mm	314 310 62
	2	Ball bearing	314 500 72 *)
	2	Seal V- Ring	
	1	Felt ring seal	
	1	Magnetic powder 460 g/ 80 µ	
	1	Magnetic powder 460 g/ 80 µ	314 510 30

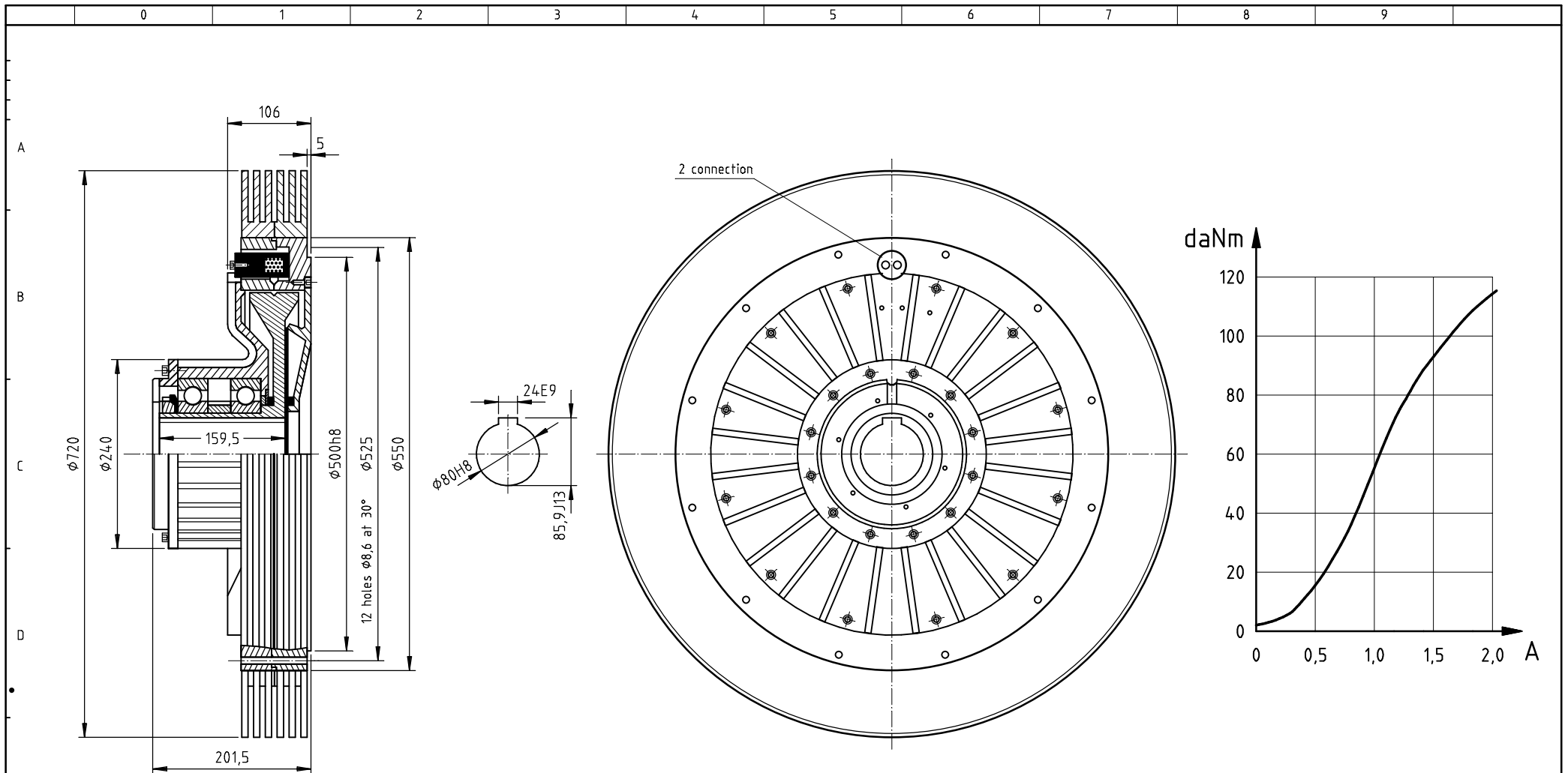

In order to avoid magnetic leakage flux and to achieve a good heat removal, non-ferrous metals should be used for installation or attachment of auxiliary components (not for drive shaft).

Only applicable for horizontal shaft position !

dimensions and specifications subject to change

rated torque	residual torque	field values			resistance at 20°C	operating times		max. admissible power loss			mass moment of inertia		weight
		maximum values	rated current			t _{on} [ms]	t _{off} [ms]	0 min ⁻¹	1000 min ⁻¹	2000 min ⁻¹	ext. rotor	int. rotor	
M _{max} [Nm]	M _{res} [Nm]	P [W]	U [V]	I _N [A]	R [Ω]	t _{on} [ms]	t _{off} [ms]	P _v [W]	P _v [W]	P _v [W]	J [kgm ²]	J [kgm ²]	m [kg]
1000	10	200	24	1,7	20	5000	4600	1700	3000*	-	-	0,81	135
								7000**					160*
													143**

*) heat sink "R"
 **) Ventilator "V"