

Please read carefully before starting operation !

1. Should any damage occur due to disregard of the following instructions the guarantee expires and the manufacturer is free from any obligations. The device can only be employed under operations parameters not exceeding the nominal capacity of the clutch or brake. Maximum torque and highest permissible power loss must be strictly observed. The available voltage must correspond to the operation voltage indicated on the identification plate. When a clutch of the E(R)AT ... -Type is used, the distance between the brush holders and the slide ring must correspond to the measure indicated on the table of dimensions. If a brake is used, there is no slide ring and the connection is effectuated directly on the coil. Thereupon it must be checked that no body contact takes place. If a clutch or a brake is operated in an extremely dustladen place (soot, wood chip, paper or cement dust) a dust cover should be provided. In such a case an additional fan should allow reliable dissipation of the heat developed.

Storage : Clutches and brakes must be stored in a dry place and protected against corrosion. The device can only be stored in its welded plastic hull containing moisture absorbing chips.

2. Installation :
Installation of the device must be carried out with care in order to prevent damaging of bearing and packing. Any use of force impairs the function. The borehole present should be lightly smeared with a rust proofing grease. The system being lubricated for life, any other lubrication with oil or grease is not admitted as it would impair the performance of the device.

3. Starting operation :
Clutches and brakes should be taken into operation by means of short current pulses to allow proper distribution of the magnetic particles. Thereupon the rotor speed correspond to the use required.

4. Dismounting, Repairs :
Instructions for repair are supplied on request free of obligation. Upon disassembly of clutches and brakes any shock by knocks and shoves must be prevented. When removing the rotor a brace can be used.

c			Datum	29.12.1993	Zeichnungsnummer/ drawing number			operating instructions	Komm.Nr		Vertragsnummer
b			Bearb.	KIPP	1.1232E						
a			Gepr.								
	Änderung	Datum	Name	Norm	Einbauort:	Ersatz fuer:	Ursprung:	05.01.2015	General-Information		Blatt 1
										1 Bl.	

Repair instructions:

Clutches	EAT 650	322 300 00	ERAT 650	322 400 00
	EAT 650 RR	322 340 00	ERAT 650 RR	322 350 00

Brakes	FAT 650	322 100 00	FRAT 650	322 200 00
	FAT 650 RR	322 110 00	FRAT 650 RR	322 230 00
			FRATO 650	322 500 00

"R" = heat sink
 "RR" = remnant rotor
 "O" = watercooling

The magnetic particle clutch / brake should be disassembled in the following order :

During assembly, refer to the sectional drawing.

1. To disassemble, place the clutch / brake on a workbench with the slipring or coil connectors up. Disconnect the slipring from the coil, and remove the screws to lift the slipring from the housing.
2. Remove the circlip rings from the internal rotor, remove the screws, and take apart the housing. This leaves the housing halves, the coil, the brass ring and the internal rotor as separate parts.
3. After removing the circlip rings from the ball bearing, lift the ball bearings and seals from the housing half.
4. Clean the inner sides of the housing halves and the internal rotor carefully of magnetic powder.
5. Fit the new seals and ball bearings in the housing halves and fix them using circlip rings. Then slide the seals (V-ring) on the hollow shaft of the internal rotor. Push the internal rotor into the ball bearing of a housing half and fix it in position using a circlip ring.
6. Housings fitted with heat sink, e.g. Type ERAT ... FRAT... have the heat sinks shrunk on. Heat them slightly if they need to be pulled off. As clutches are balanced with the heat sink fitted, be sure to re-fit it in exactly the same position.

Important note !

The magnetic powder must be poured into the air gap / space between the internal rotor and the external rotor (not into the hollow space in which the field coil is located). Be sure to use only the amount and particle size of magnetic powder approved for the particular type of clutch / brake.

The old magnetic powder must not be re-used.

Then insert the coil and brass ring, replace the second housing half and screw it down. Then insert the circlip ring on the opposite side, secure the slipring assembly and make the connections with the coil.

Spare parts :

*) Only available as a complete repair kit

Item	Pcs	Type 650	Stock-No.
3	1	Internal rotor	315 500 03
7	1	Field coil 24 VDC	322 100 07
60	1	Brush holder assy.	807 275 02
40	1	Slipring	315 300 42
-	4	Carbon brush with connecting tag 3x4x13mm	130 518 189
15	2	Ball bearing	812 030 00 *)
14	2	V- ring seal	
6	2	Felt ring seal	
16	-	Magnetic powder 35 gr / 50µ	322 300 16

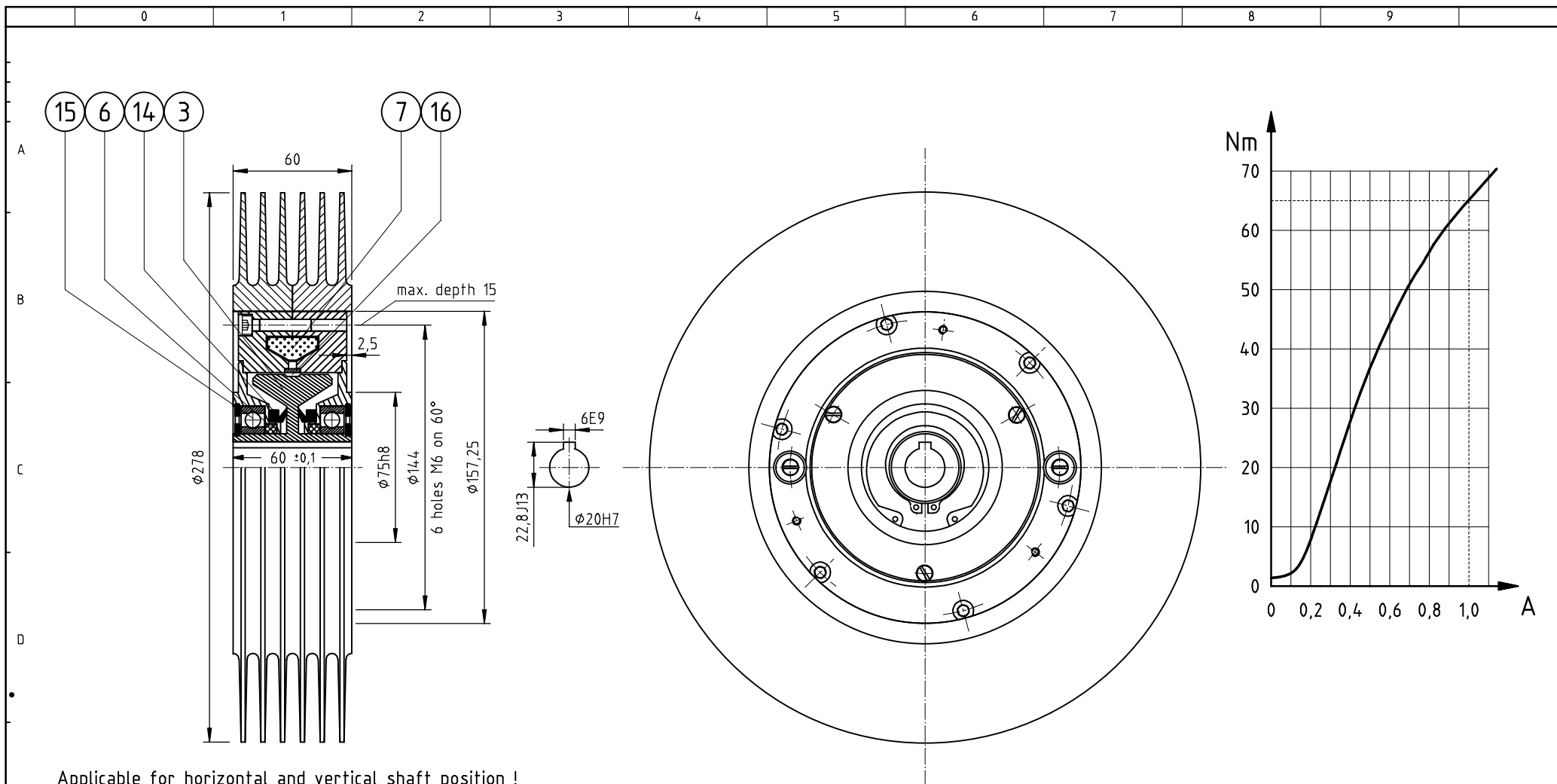

Applicable for horizontal and vertical shaft position !

In order to avoid magnetic leakage flux and to achieve a good heat removal, non-ferrous metals should be used for installation or attachment of auxiliary components (not for drive shaft).
dimensions and specifications subject to change

rated torque	residual torque	field values			resistance at 20°C	operating times		axial force is inadmissible			admissible max. radial force: 1,02 kN		
		maximum values		rated current		t _{on} [ms]	t _{off} [ms]	max. admissible power loss			mass moment of inertia		weight
		P [W]	U [V]	I _N [A]				R [Ω]	0 min ⁻¹	1000 min ⁻¹	2000 min ⁻¹	ext. rotor	
M _{max} [Nm]	M _{res} [Nm]	P [W]	U [V]	I _N [A]	R [Ω]	t _{on} [ms]	t _{off} [ms]	P _V [W]	P _V [W]	P _V [W]	J [kgm ²]	J [kgm ²]	m [kg]
65	1,30	30	24	1	20	520	355	150 350*	-	-	-	2,0·10 ⁻³	7,2 11,0*

*) heat sink "R"

item	amount	parts
3	1	internal rotor
6	2	felt gasket
7	1	field coil 24VDC
14	2	V ring gasket
15	2	ball bearing
16	-	air gap for magnetic powder

