

Please read carefully before starting operation !

- Should any damage occur due to disregard of the following instructions the guarantee expires and the manufacturer is free from any obligations. The device can only be employed under operations parameters not exceeding the nominal capacity of the clutch or brake. Maximum torque and highest permissible power loss must be strictly observed. The available voltage must correspond to the operation voltage indicated on the identification plate. When a clutch of the E(R)AT ... -Type is used, the distance between the brush holders and the slide ring must correspond to the measure indicated on the table of dimensions.
 If a brake is used, there is no slide ring and the connection is effectuated directly on the coil. Thereupon it must be checked that no body contact takes place.
 If a clutch or a brake is operated in an extremely dustladen place (soot, wood chip, paper or cement dust) a dust cover should be provided. In such a case an additional fan should allow reliable dissipation of the heat developed.

Storage : Clutches and brakes must be stored in a dry place and protected against corrosion. The device can only be stored in its welded plastic hull containing moisture absorbing chips.

- Installation :
 Installation of the device must be carried out with care in order to prevent damaging of bearing and packing. Any use of force impairs the function. The borehole present should be lightly smeared with a rust proofing grease. The system being lubricated for life, any other lubrication with oil or grease is not admitted as it would impair the performance of the device.
- Starting operation :
 Clutches and brakes should be taken into operation by means of short current pulses to allow proper distribution of the magnetic particles. Thereupon the rotor speed correspond to the use required.
- Dismounting, Repairs :
 Instructions for repair are supplied on request free of obligation. Upon disassembly of clutches and brakes any shock by knocks and shoves must be prevented. When removing the rotor a brace can be used.

c			Datum	29.12.1993	Zeichnungsnummer/ drawing number				operating instructions	Komm.Nr		Vertragsnummer
b			Bearb.	KIPP	1.1232E					General-Information		
a			Gepr.									
	Änderung	Datum	Name	Norm	Einbauort:	Ersatz fuer:	Ursprung:	09.08.2011	1 Bl.			

Repair instructions :

Clutches EAT 120 321 500 00 ERAT 120 321 600 00
 EAT 120 RR 321 340 00 ERAT 120 RR 321 620 00

Brakes FAT 120 321 300 00 FRAT 120 321 400 00
 FAT 120 RR 321 330 00 FRAT 120 RR 321 440 00
 FRATO 120 321 420 00

“R” = heat sink
 “RR”= remnant rotor
 “O” = watercooling

The magnetic particle clutch / brake should be disassembled in the following order :

During assembly, refer to the sectional drawing.

1. To disassemble, place the clutch / brake on a workbench with the slipping or coil connectors up. Disconnect the slipping from the coil, and remove the screws to lift the slipping from the housing.
2. Remove the circlip rings from the internal rotor, remove the screws, and take apart the housing. This leaves the housing halves, the coil, the brass ring and the internal rotor as separate parts.
3. After removing the circlip rings from the ball bearing, lift the ball bearings and seals from the housing half.
4. Clean the inner sides of the housing halves and the internal rotor carefully of magnetic powder.
5. Fit the new seals and ball bearings in the housing halves and fix them using circlip rings. Then slide the seals (V-ring) on the hollow shaft of the internal rotor. Push the internal rotor into the ball bearing of a housing half and fix it in position using a circlip ring.
6. Housings fitted with heat sink, e.g. Type ERAT ... FRAT... have the heat sinks shrunk on. Heat them slightly if they need to be pulled off. As clutches are balanced with the heat sink fitted, be sure to re-fit it in exactly the same position.

Important note !

The magnetic powder must be poured into the air gap / space between the internal rotor and the external rotor (not into the hollow space in which the field coil is located). Be sure to use only the amount and particle size of magnetic powder approved for the particular type of clutch / brake.

The old magnetic powder must not be re-used.

Then insert the coil and brass ring, replace the second housing half and screw it down. Then insert the circlip ring on the opposite side, secure the slipping assembly and make the connections with the coil.

Spare parts :

*) Only available as a complete repair kit

Item	Pcs	Type 120	Stock-No.
3	1	Internal rotor	315 300 03
7	1	Field coil 24 VDC	321 300 07
60	1	Brush holder assy.	807 275 02
40	1	Slipping	315 300 40
-	4	Carbon brush with connecting tag 3x4x13mm	130 518 189
15	2	Ball bearing	812 010 00 *)
14	2	V- ring seal	
6	2	Felt ring seal	
16	-	Magnetic powder 15 gr / 50μ	321 500 16

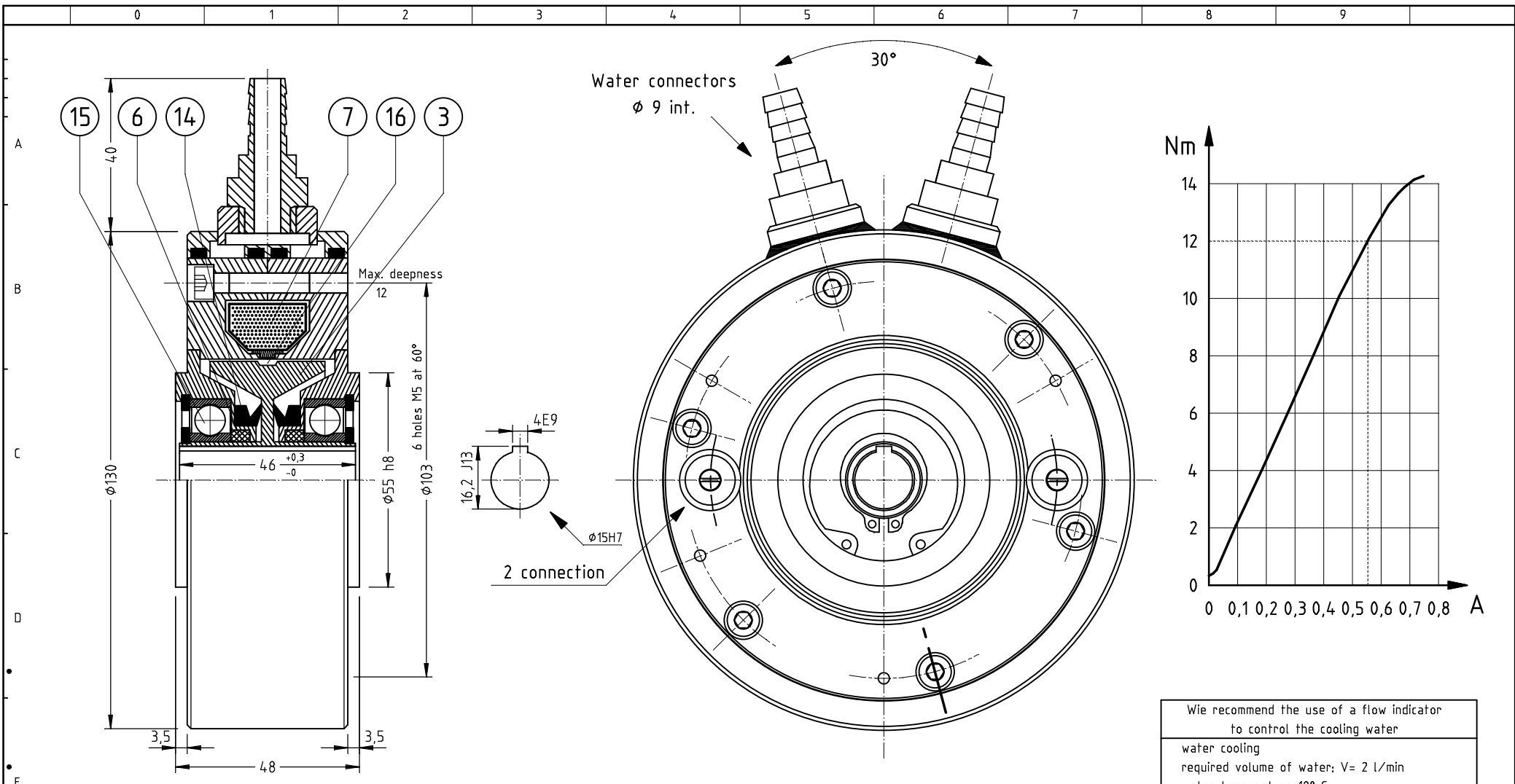

In order to avoid magnetic leakage flux and to achieve a good heat removal, non-ferrous metals should be used for installation or attachment of auxiliary components (not for drive shaft).
 dimensions and specifications subjekt to change

Only applicable for horizontal shaft position !

rated torque	residual torque	field values			resistance at 20°C	operating times		max. admissible power loss			mass moment of inertia		weight
		maximum values	rated current			t_{on} [ms]	t_{off} [ms]	0 min ⁻¹	1000 min ⁻¹	2000 min ⁻¹	ext. rotor	int. rotor	
M_{max} [Nm]	M_{res} [Nm]	P [W]	U [V]	I_N [A]	R [Ω]			P_v [W]	P_v [W]	P_v [W]	J [kgm ²]	J [kgm ²]	m [kg]
12	0,27	24	24	0,55	23	240	150	400	-	-	-	$0,25 \cdot 10^{-3}$	3,4

Wie recommend the use of a flow indicator to control the cooling water		
water cooling		
required volume of water: V= 2 l/min		
water temperature 18° C		
water pressure app 3 bar		
pH- value < 8		
item	amount	parts
3	1	internal rotor
6	2	felt gasket
7	1	field coils 24 VDC
14	2	V- ring gasket
15	2	ball bearing
16	-	air gap for magnetic powder