

A
B
C
D

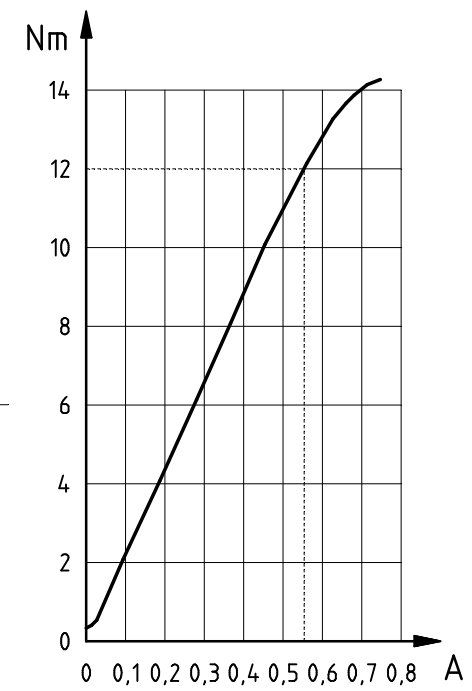
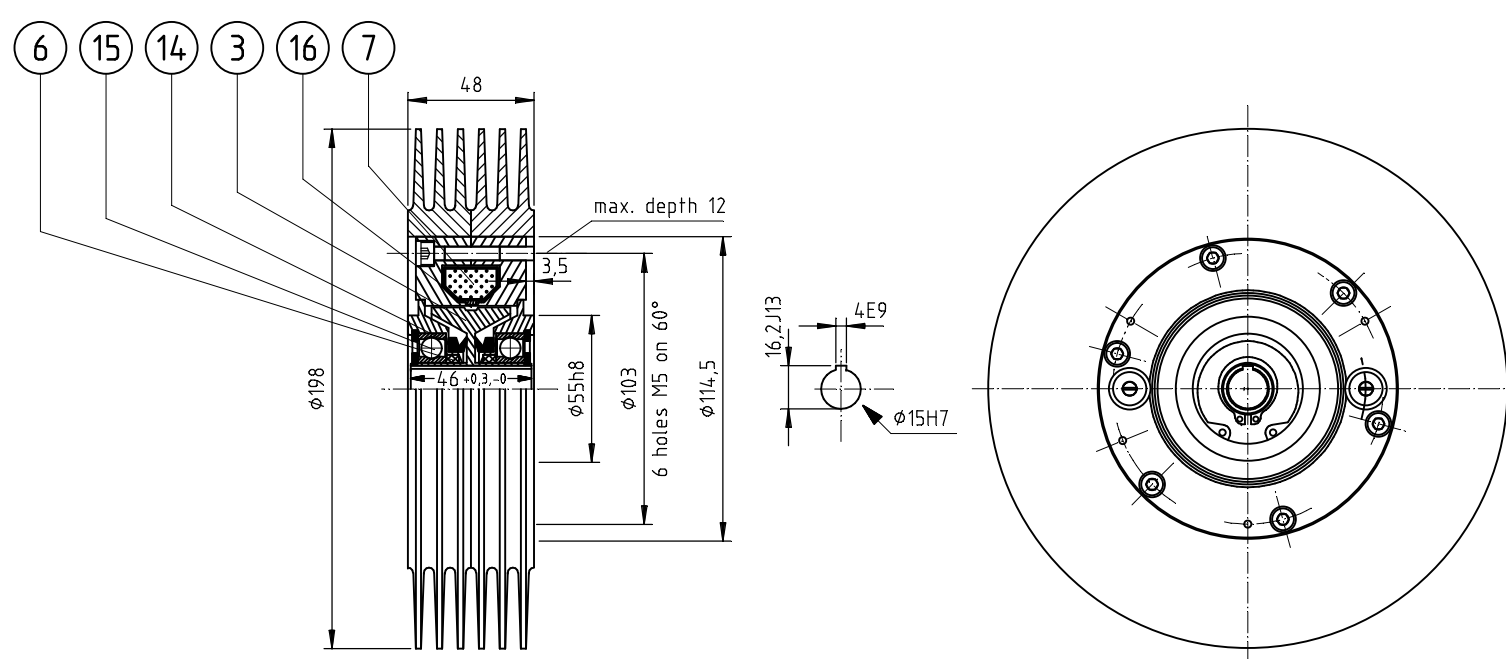

Only applicable for horizontal shaft position !

In order to avoid magnetic leakage flux and to achieve a good heat removal, non-ferrous metals should be used for installation or attachment of auxiliary components (not for drive shaft).

dimensions and specifications subjekt to change

rated torque	residual torque	field values			resistance at 20°C	operating times		axial force is inadmissible			admissible max. radial force: 500 N			
		maximum values		rated current		t _{on} [ms]	t _{off} [ms]	max. admissible power loss			mass moment of inertia		weight	
		P [W]	U [V]					I _N [A]	R [Ω]	0 min ⁻¹	1000 min ⁻¹	2000 min ⁻¹		ext. rotor
M _{max} [Nm]	M _{res} [Nm]	P [W]	U [V]	I _N [A]	R [Ω]	t _{on} [ms]	t _{off} [ms]	P _v [W]	P _v [W]	P _v [W]	J [kgm ²]	J [kgm ²]	m [kg]	
12	0,27	24	24	0,55	23	240	150	75	150*	-	-	-	0,25·10 ⁻³	2,6
														4,4**
														5,5**

*) heat sink "R"

***) ventilator "V"

item	amount	parts
3	1	internal rotor
6	2	felt gasket
7	1	field coil 24VDC
14	2	V ring gasket
15	2	ball bearing
16	-	air gap for magnetic powder