

A
B
C
D
E

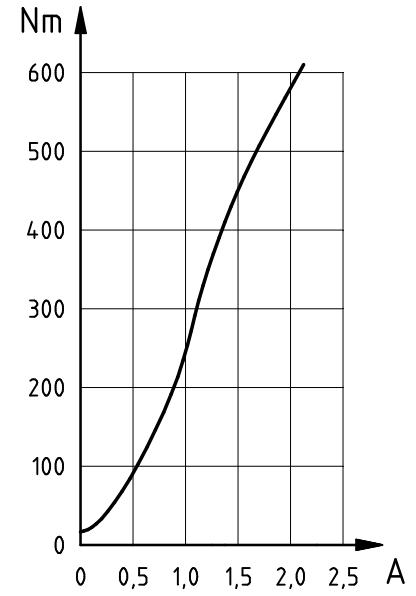
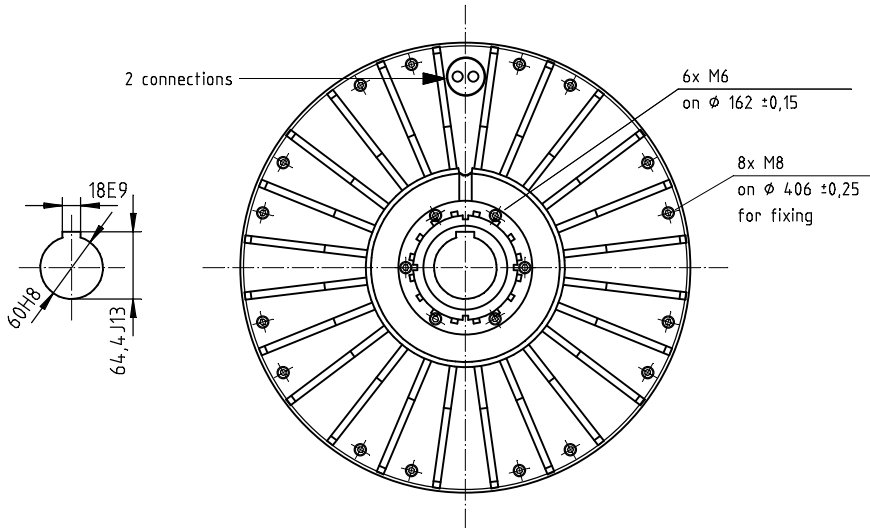
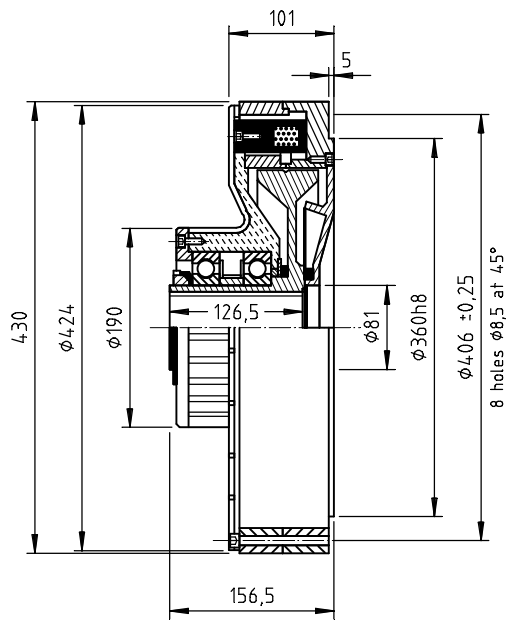

In order to avoid magnetic leakage flux and to achieve a good heat removal, non-ferrous metals should be used for installation or attachment of auxiliary components (not for drive shaft).

Only applicable for horizontal shaft position !

dimensions and specifications subject to change

rated torque	residual torque	field values			resistance at 20°C	operating times		max. admissible power loss			mass moment of inertia		weight
		maximum values	rated current			t _{on} [ms]	t _{off} [ms]	0 min ⁻¹	1000 min ⁻¹	2000 min ⁻¹	ext. rotor	int. rotor	
M _{max} [Nm]	M _{res} [Nm]	P [W]	U [V]	I _N [A]	R [Ω]	t _{on} [ms]	t _{off} [ms]	P _v [W]	P _v [W]	P _v [W]	J [kgm ²]	J [kgm ²]	m [kg]
500	5,0	55	24	1,7	11	3000	2750	1000	-	-	-	0,33	73,0